

BS222R EXPLODED VIEW

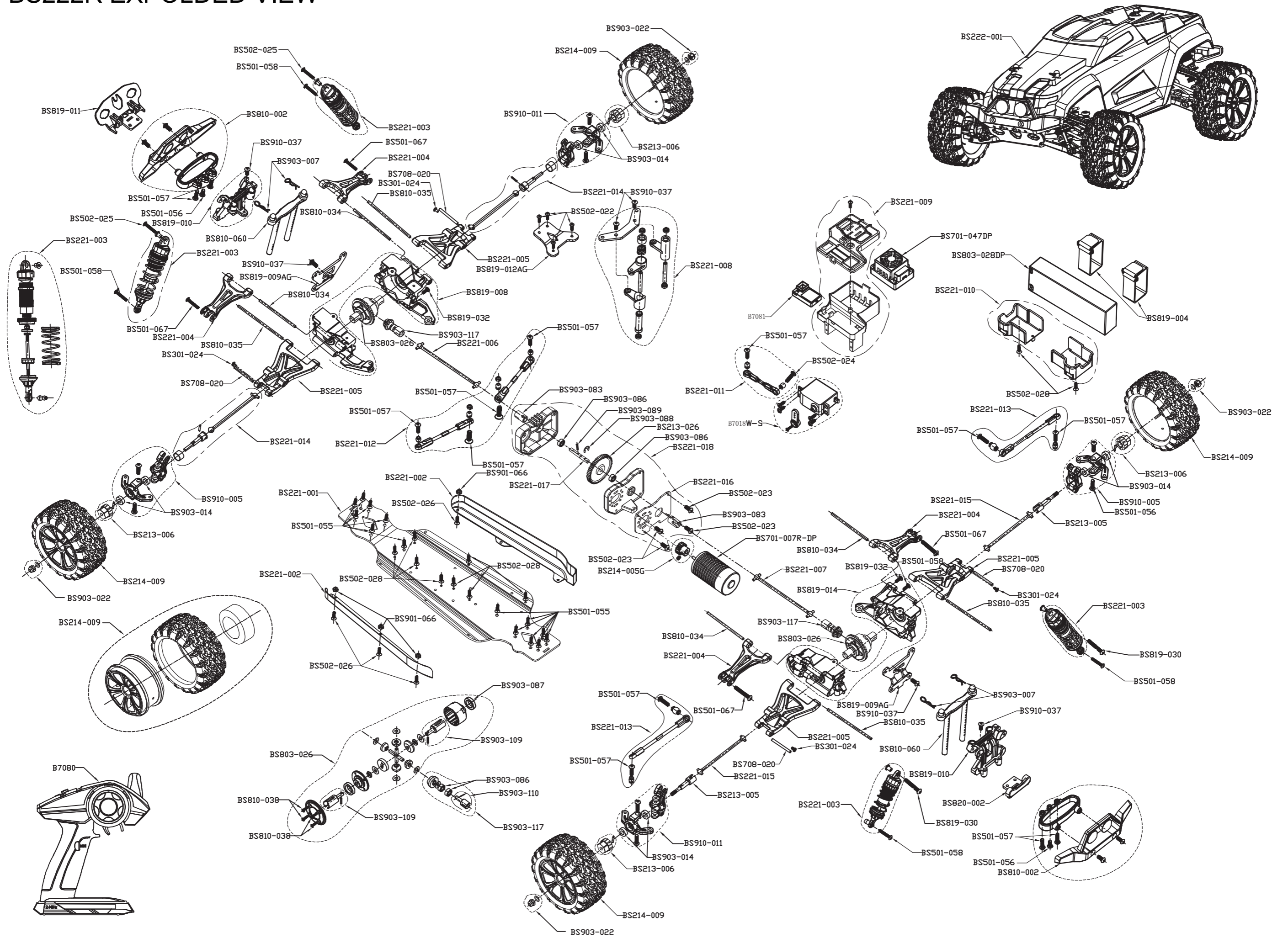

BS222T/BS222R COMMON PARTS

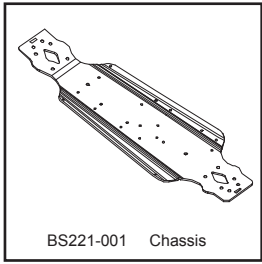

BS221-001 Chassis

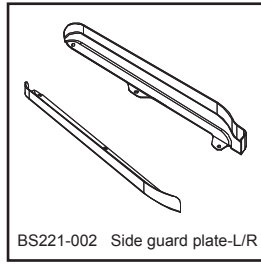

BS221-002 Side guard plate-L/R

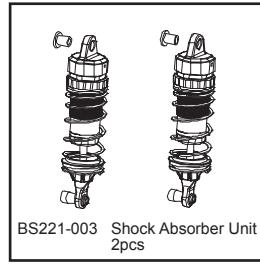

BS221-003 Shock Absorber Unit 2pcs

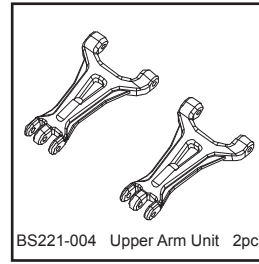

BS221-004 Upper Arm Unit 2pcs

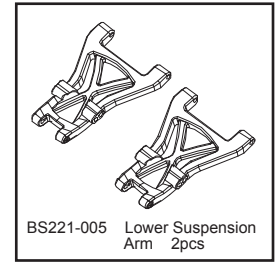

BS221-005 Lower Suspension Arm 2pcs

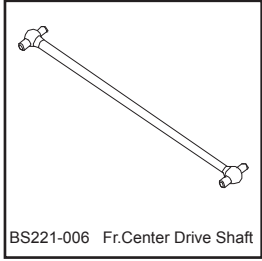

BS221-006 Fr.Center Drive Shaft

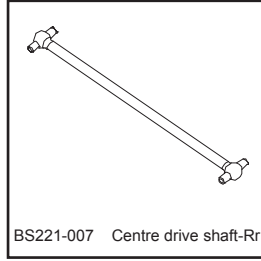

BS221-007 Centre drive shaft-Rr

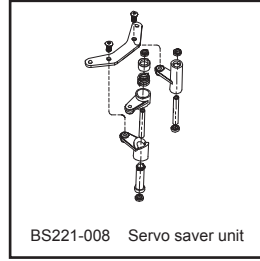

BS221-008 Servo saver unit

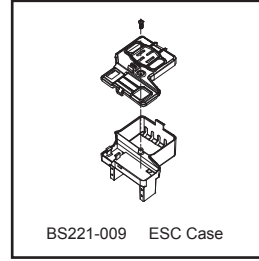

BS221-009 ESC Case

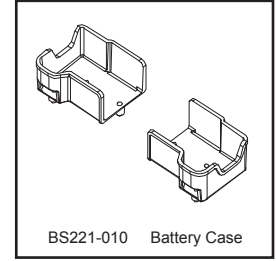

BS221-010 Battery Case

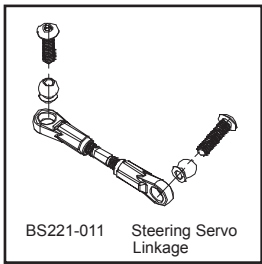

BS221-011 Steering Servo Linkage

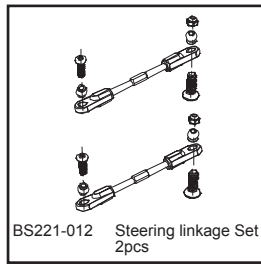

BS221-012 Steering linkage Set 2pcs

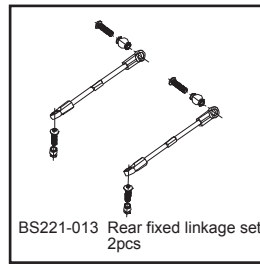

BS221-013 Rear fixed linkage set 2pcs

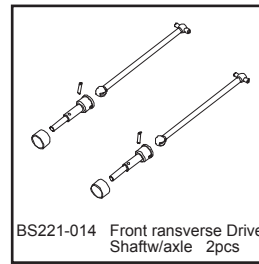

BS221-014 Front ransverse Drive Shaftw/axle 2pcs

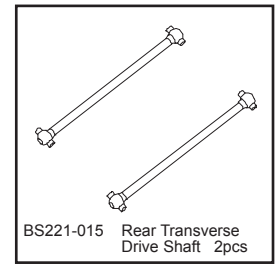

BS221-015 Rear Transverse Drive Shaft 2pcs

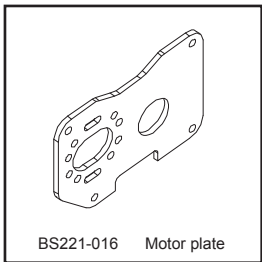

BS221-016 Motor plate

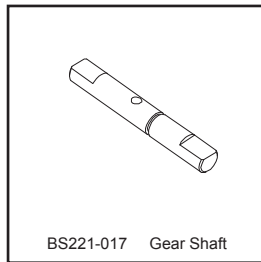

BS221-017 Gear Shaft

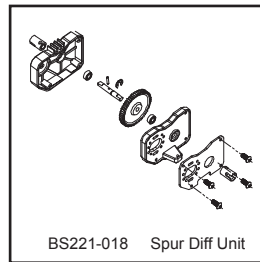

BS221-018 Spur Diff Unit

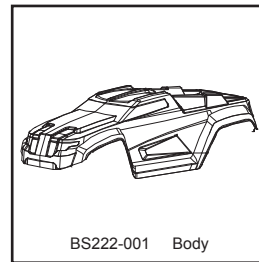

BS222-001 Body

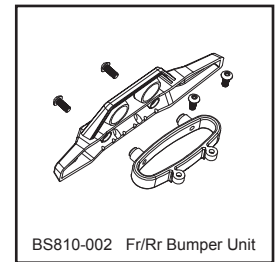

BS810-002 Fr/Rr Bumper Unit

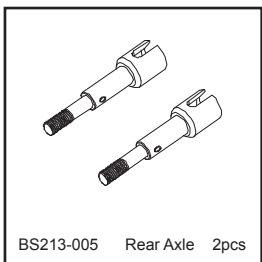

BS213-005 Rear Axle 2pcs

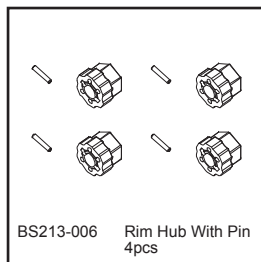

BS213-006 Rim Hub With Pin 4pcs

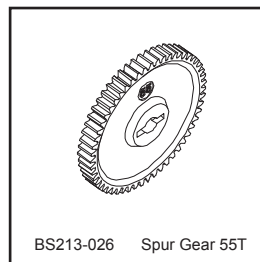

BS213-026 Spur Gear 55T

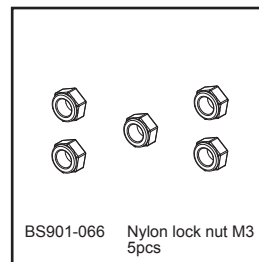

BS901-066 Nylon lock nut M3 5pcs

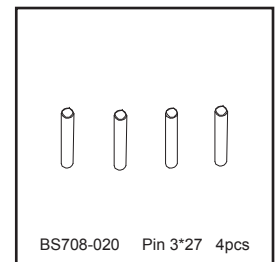

BS708-020 Pin 3*27 4pcs

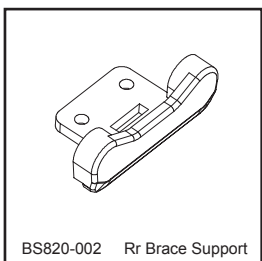

BS820-002 Rr Brace Support

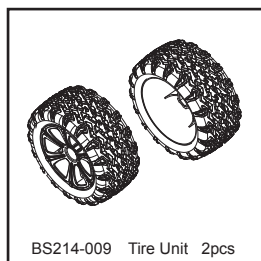

BS214-009 Tire Unit 2pcs

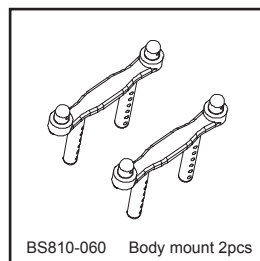

BS810-060 Body mount 2pcs

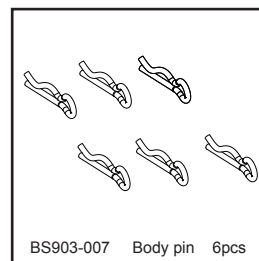

BS903-007 Body pin 6pcs

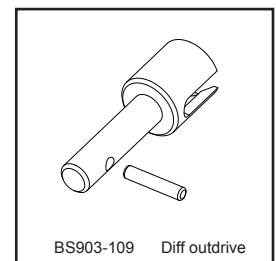

BS903-109 Diff outdrive

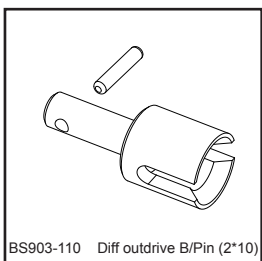

BS903-110 Diff outdrive B/Pin (2*10)

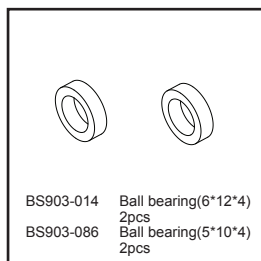

BS903-014 Ball bearing(6*12*4) 2pcs
BS903-086 Ball bearing(5*10*4) 2pcs

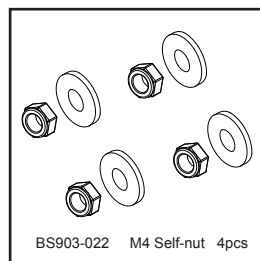

BS903-022 M4 Self-nut 4pcs

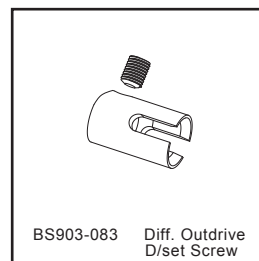

BS903-083 Diff. Outdrive D/set Screw

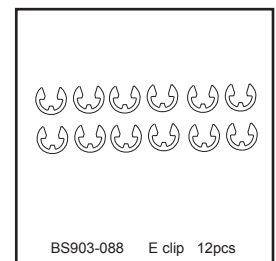

BS903-088 E clip 12pcs

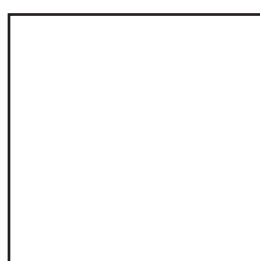
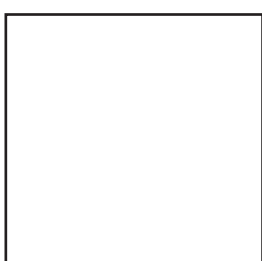
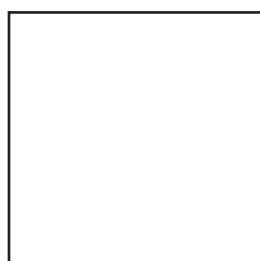
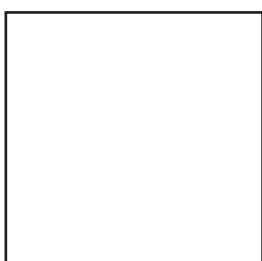
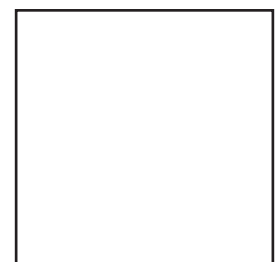
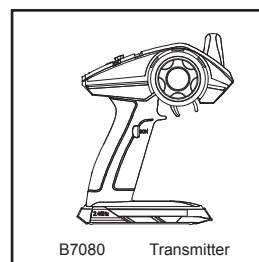
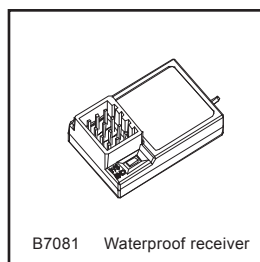
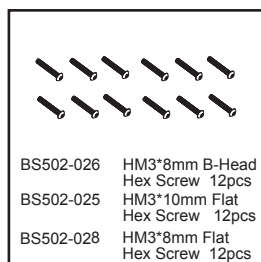
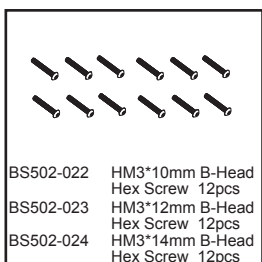
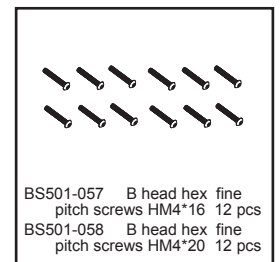
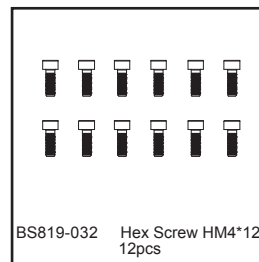
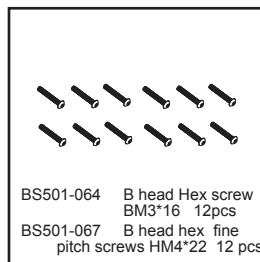
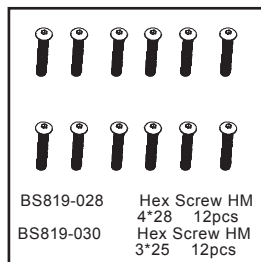
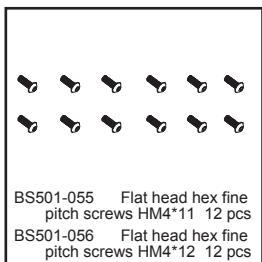
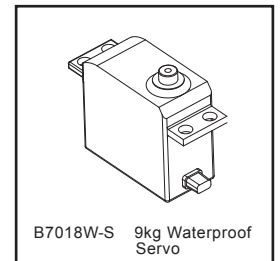
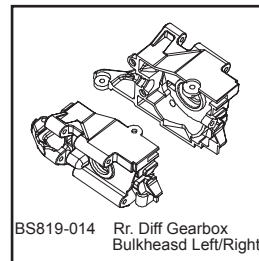
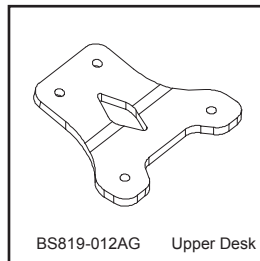
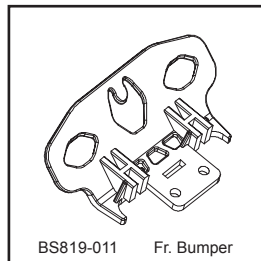
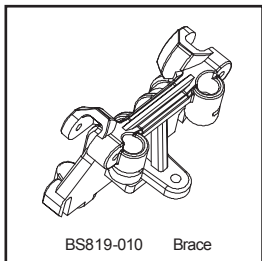
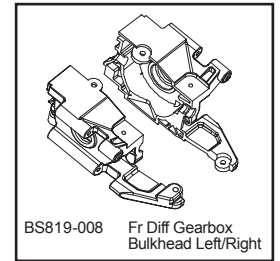
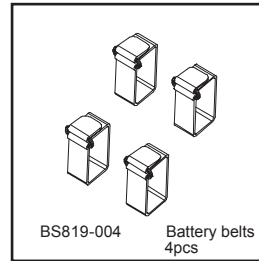
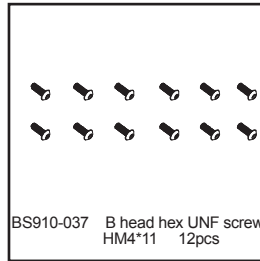
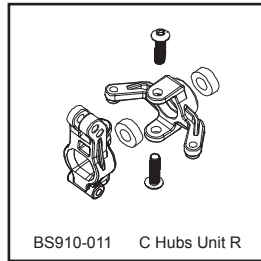
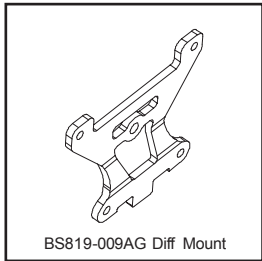
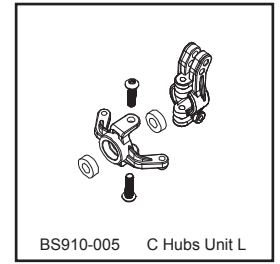
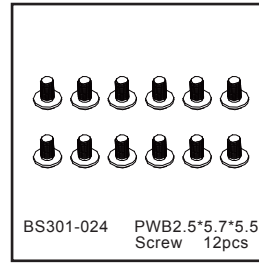
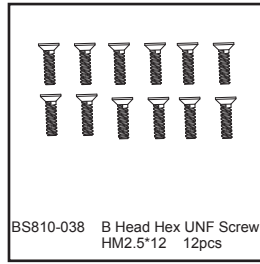
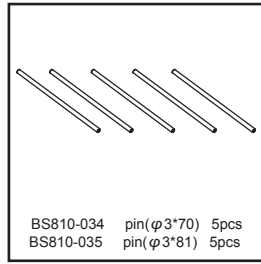
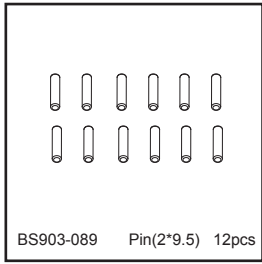

BS222T/BS222R COMMON PARTS

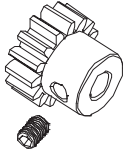
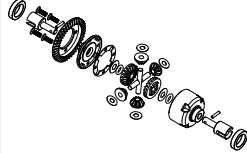
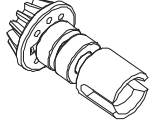
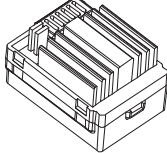
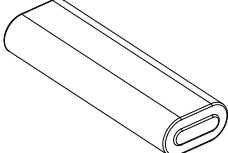
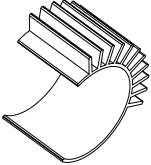
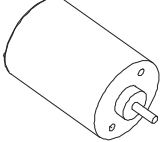

BS222T PARTS

 <p>BS221-020 17T Motor Gear</p>	 <p>BS903-104 Diff. Gear Box Unit (zinc alloy)</p>	 <p>BS903-116 Master Gear Unit (Zinc Alloy)</p>	 <p>B7003W 1/10 Brushed Waterproof Esc (Tamiya head)</p>	 <p>BS701-036C 7.2V 1800MAH Battery</p>
 <p>BS701-008AG Motor Heat Sink</p>	 <p>BS701-007 550 Motor</p>			

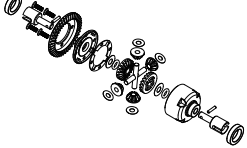
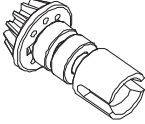
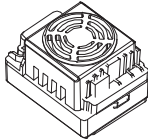
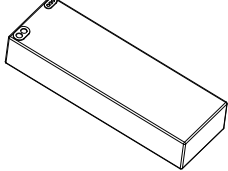
BS222R PARTS

 <p>BS214-005G Motor Gear 17T</p>	 <p>BS803-026 Diff. Gear Box Unit(steel)</p>	 <p>BS903-117 Master Gear Unit (steel)</p>	 <p>BS701-047DP 45A Brushless Waterproof Esc</p>	 <p>BS803-028DP 7.4V 3200 mAh Battery (T head)</p>
 <p>BS701-007R-DP 540 Brushless Motor KV3421</p>				